



## VENTILATORS (H-RV/H-SV)

### Contact Info

sales@apexengineering.co.za  
info@apexengineering.co.za



## RIDGE/SLOPE MOUNTED

+27 60 686 9936  
+27 79 757 8489



www.apexengineering.co.za



2024





## H-RV & H-SV

### Standard Range

Model	A	B	C	D
H-SV / RV	300	360	800	860
H-SV / RV	460	360	900	960
H-SV / RV	600	470	1100	1150
H-SV / RV	750	585	1200	1250
H-SV / RV	900	650	1400	1450

### Dimensions (mm)

*PLEASE NOTE: Units available in modules up to 2450 mm long.*

*Larger throat openings available on request.*

Slope and Ridge Mounted Ventilators are backed by Helm's national experience, gathered over more than 30 years of manufacturing and supplying products to the industry.

As natural ventilators, the units will be weather tight under all normal positive pressure conditions, will be capable of withstanding a wind load of 1,5 Kn/m<sup>2</sup> and will have a free area of exhaust at least equal to the throat opening.

*PLEASE NOTE: Bird proofing and burglar bars as well as electronic or pneumatic controls are available as optional extras.*

Helm accepts undivided responsibility for research, design and engineering, manufacture, delivery and erection of their complete product range.

**Ventilators can be constructed from either:**

Galvanised, aluminium, stainless steel and pre-painted material. An embossed finish is also available on request.

## Applications

The H-SV ventilator is commonly used throughout all types of industry and has many other applications in buildings such as schools, hospitals, hostels, etc. where efficient extraction is required without any noise on the slope of the roof.

The H-RV ventilator is commonly used throughout the industry and has many other applications in larger buildings such as warehouses, distribution centres etc. It is where efficient extraction is required along the ridge of the roof.

## Description

Ridge / Slope Mounted Ventilators are natural extract roof mounted units. It ensures positive extraction under all weather conditions being so designed that all rain is effectively drained. It is suitable for the general ventilation of all industrial buildings.

Since it operates without running costs it is particularly useful in industries where continuous extraction of plant and solar heat is needed.

## Performance tested

The Helm Ridge / Slope Mounted Ventilators has been fully tested by an Independent Test Authority. Coefficient of discharge = 0,4

## Standard Range

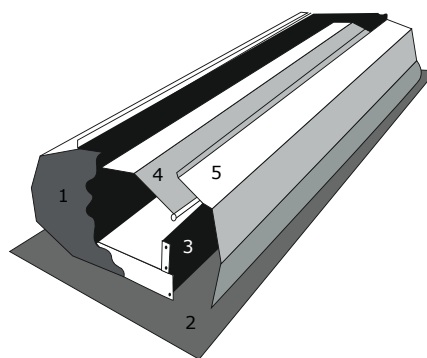
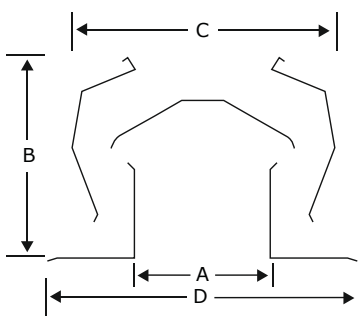

- 1 End Cap
- 2 Base Flange
- 3 Side Stack
- 4 Weathering Cap
- 5 Suction Band





## Installation

May be fixed into all types of roofing e.g. profiled sheet, concrete, either flat or pitched roofs. Detail drawings and/or fixing instructions are available on request.

## Abridged air change table

SITUATION	Air changes per hour*
Boiler Houses	20 - 30
Compressor Rooms	30 - 60
Engine Rooms	20 - 30
Factories (Workshops)	6 - 10
Furnace Shops	30 - 60
Garages	8 - 12
Kitchens (Commercial)	15 - 20
Laboratories	4 - 6
Machine Shops	6 - 10
Paint Shops	30 - 60
Poultry Houses	6 - 10
Warehouses	4 - 8

\*The air changes up to eight times an hour, providing removal of contamination typically caused by human occupants. The higher rates of air changes provide for removing heat and steam in temperate zones. In hot climates the air changes per hour should at least be doubled. Apex accepts undivided responsibility for research, design and engineering, manufacture, delivery and erection of their complete product range.

*PLEASE NOTE: Due to our ongoing research and development programme, we reserve the right to supply products which may differ slightly from those illustrated and described in this brochure.*

