



APEX ORION

EN12101-2 SMOKE VENTILATOR

Contact Info

sales@apexengineering.co.za
info@apexengineering.co.za



+27 60 686 9936
+27 79 757 8489



www.apexengineering.co.za



2026





EN12101-2 CERTIFIED SMOKE VENTILATOR



Apex Engineering is a specialist smoke ventilation & extraction company that provides Architects and Engineers with the best product solutions for their smoke ventilation projects. We offer full Turnkey solutions for Smoke, Heat Extraction & Ventilation System – (SHEVS), from inception to design, fabrication & installation. Our smoke ventilation/extraction products are designed & installed in accordance with SANS10400 and comply with the relevant parts of EN12101.

Apex ORION smoke ventilators are manufactured from various roofing materials including stainless steel and aluminium and complies with EN12101-2. The smoke ventilators are designed to operate with a 24 V DC actuator, wired to a SHEVS Control panel. Apex ORION is available in standard sizes and is built with a Failsafe Fusible Link available in various temperature selections.

Engineered Smoke Control Systems are a key installation in many commercial buildings to safeguard occupants' safety. They include smoke curtains as well as ventilator systems, which help to channel smoke movement towards extraction points as well as remove them from building interiors.

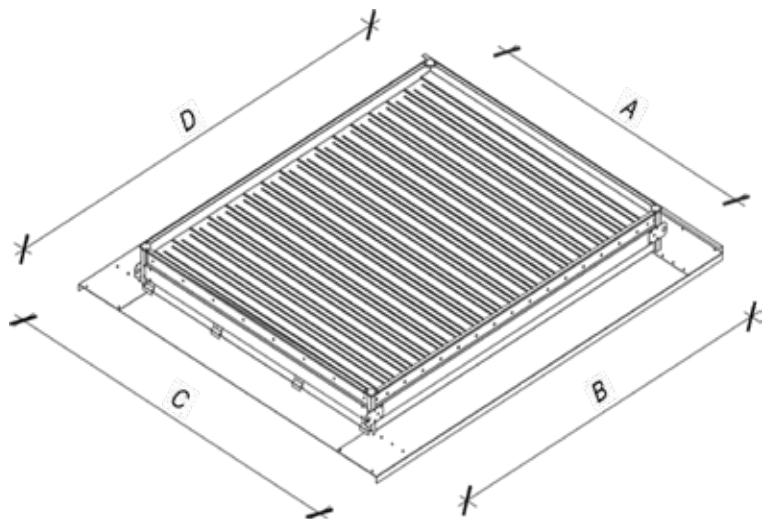



FOR THE ENGINEER



The Features

- Natural day-to-day ventilation.
- Natural smoke exhaust in case of fire.
- No fan power consumption required.
- Compliance with the EN 12101-2.
- CE certified, for all options.

Performances & Classification

Certified by an independent test laboratory, according to EN 12101-2 standard

- Aerodynamic free area: see table
- Reliability: Re100
- Low ambient temperature: T(00)
- Wind load: WL 2300
- Resistance to heat: B 300
- Reaction to fire classification (steel): A1

The Specifications

All options of the Orion are certified.

- Material: ZincAlume or Galvanised
- Standard Chromadek© Z200, Chromadek©Z275 Ultim
- Galvanised, ZincAlume, Colour Plus AZ150,AZ200
- Standard RAL colours available
- Installation angle: Flat roof up to 15° inclination or monitor of 45°
- Opening mechanism: 24V linear actuator or 24V spring return actuator
- Including battery backup
- Fusible link temperatures: 74°C, 100°C, 138°C, 182°C or 232°C
- Up-stand of 150 mm possible
- Wind deflector of 50 mm height possible
- Extended width possible
- Optional: bird mesh, burglar bars and dust seals

ORION	A10	A12	A14	A15	B10	B12	B14	B15
Measured Throat Area (Av) in m ²	1,83	2,18	2,53	2,7	2,25	2,68	3,11	3,32
Discharge Coefficient (CvO)	0,59	0,59	0,58	0,57	0,60	0,60	0,56	0,55
Throat Width & Length in mm(B & A)	1394 x 1316	1660 x 1316	1926 x 1316	2059 x 1316	1394 x 1616	1660 x 1616	1926 x 1616	2059 x 1616
Total Width & Length in mm (D & C)	1916 x 1794	1916 x 2060	1916 x 2326	1916 x 2459	2216 x 1794	2216 x 2060	2216 x 2326	2216 x 2459
Total Height in mm	250	250	250	250	250	250	250	250
Quantity of Blades	10	12	14	15	10	12	14	15
Recommended Purlin Spacing in mm	1400	1600	1900	2000	1400	1600	1900	2000
Mass in kg	49	60	68	73	61	72	84	90



Aerodynamic Free Area - m²

Code	Without Wind Baffle								With Wind Baffle			
	A10	A12	A14	A15	B10	B12	B14	B15	A14	A15	B14	B15
ORION												
Standard ventilator	1.07	1.28	1.46	1.53	1.35	1.60	1.74	1.82	1.55	1.68	1.93	2.10
With burglar bar	1.02	1.23	1.40	1.47	1.29	1.53	1.67	1.75	1.48	1.61	1.85	2.01
With bird mesh	0.94	1.13	1.29	1.35	1.19	1.41	1.53	1.61	1.35	1.46	1.68	1.82
With burglar bar and bird mesh	0.91	1.08	1.24	1.30	1.14	1.36	1.48	1.54	1.29	1.40	1.61	1.75

TYPICAL ROOF INSTALLATION

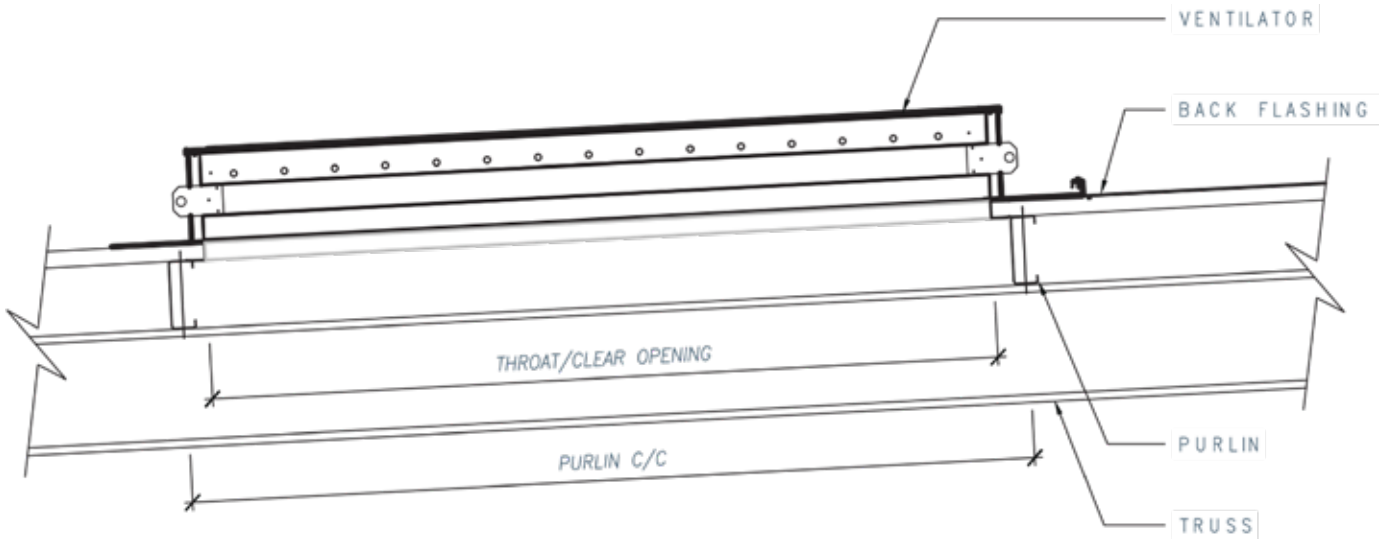



QUICK REFERENCE MATERIAL GUIDE

Choosing the best material for smoke ventilators can be a challenging task for engineers. There are several factors to consider, including the climate of the area, the durability of the material, and its aesthetic appeal.

It's important to consider the location/Zone & climate of the area when choosing the type of material, as extreme temperatures and weather conditions can affect the lifespan of the smoke ventilator. Engineers should also consider the expected lifespan of the material, which could be in excess of 15-20 years depending on the type of material used.

Ultimately, engineers should carefully evaluate the requirements of the project before selecting a roofing material to ensure the best possible functionality and durability.

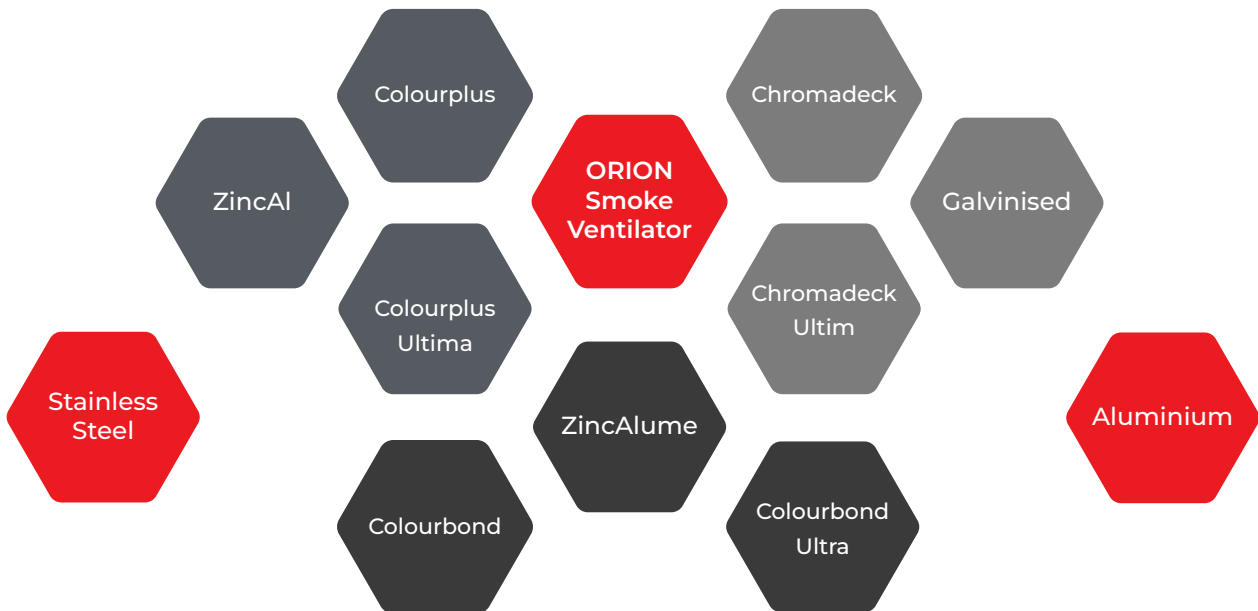

Guideline for Product Selection

	Zone C1-C2	Zone C3	Zone C4	Zone C5
	Urban, rural, low levels of airborne pollution	Light industrial, average marine corrosion	Large commercial, medium industrial or high marine corrosion	Heavy industrial or severe marine zones
	40km or more from the splash zone	1-40km from the splash zone	400m to 1km from the splash zone	100m to 400m from the splash zone
AZ 150				
AZ 200				
Z 200				
Z 275				
S/S				
Alu				





FREQUENTLY ASKED QUESTIONS

01 How long should roof ventilators last?

A variety of factors influence roof ventilators' life, including the location (Zones: C-5), type of material, quality of materials, installation quality and frequency of preventive maintenance. Apex Engineering can guide the engineer, Architect or consultant through the pre-tender phase to make the best selection of materials. With the wide variety of materials on the market, the average lifespan of roof ventilators will be between 15-20 Years

02 How do I achieve the best return on investment for roof ventilators?

Proactive preventive maintenance is of the utmost importance. By practicing preventive maintenance, your roof ventilators may exceed its warranted life. In addition to maintenance, having a roof ventilator installed the right way the first time around puts you ahead of the game. Quality materials and superior workmanship make a huge difference in the return on your roof ventilator investment.

03 Does Apex Engineering only have a set range of colours and products?

Apex Engineering can offer various ranges of material & coatings for all roof ventilator models, contact us for detailed information.



CONTACT US

FOR MORE INFORMATION

Contact Info

sales@apexengineering.co.za
info@apexengineering.co.za



+27 60 686 9936
+27 79 757 8489



www.apexengineering.co.za



2026

